

Vehicle

Booster Amplifier Installation Guide

Model:
SBX-800NXT
SBX-819
SBX-1900

Boost Cellular
Signal **1000%**



BOSTON[®]
Amplifier
your solution to wireless technology
<http://www.bostonamplifier.com>

Notice:

The information in this document is intended for informational purposes only, and is subject to change without notice. By using this product, the user assumes all risk. Any and all references to Boston Amplifier in this document, including those in the Warranty, refer to the manufacturer: Boston Amplifier, Inc.

In no event will Boston Amplifier or its affiliates be liable for direct, indirect, special, incidental, or consequential damages arising out of the use or the inability to use the product or documentation, even if advised of the possibility of such damages.

No part of this reference manual may be reproduced or transmitted, in any form, or by any means, without the prior written consent of Boston Amplifier.

Legal:

The information provided herein is believed to be completed and accurate, however, no responsibility is assumed by Boston Amplifier for any business or personal losses arising from the use of this product, nor for any infringements of patents. Boston Amplifier reserves the right to change, alter, modify or edit the specifications at anytime without notice. Other rights of the third party, which may result from its use.

Trademarks:

Throughout this User's Guide, trade names and trademarks of other companies or products may appear. This is not intended to imply or convey the endorsement of, or any affiliation of Boston Amplifier with, any of these companies or products. Boston Amplifier and Antenna Port Module are Trademarks of Boston Amplifier, Inc.

Note: This product amplifies radio frequency energy. Improper installation or use not in strict accordance with the manufacturer's instructions may result in improper operation and or potential damage to the product. There is no guarantee against the presence of interference by other transmitters and noise sources on the operating frequencies. The user is responsible for complying with all applicable federal, state, and local laws, including those pertaining to those involving allowable levels of non-ionizing radiation.

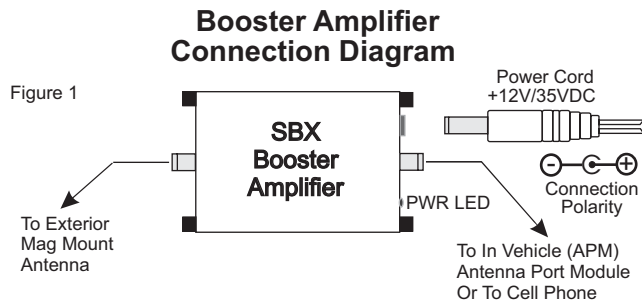

Booster Amplifier With Cradle and Antenna Port Module



Antenna Port Module (APM) can be used with a cell phone cradle when installed as follows

- 1. Place Antenna Port Module in the bottom of the cradle.*
- 2. Place cell phone in the cradle with the APM touching the back of the cell phone.*

A Bluetooth wireless or regular head set can be used for hands free communication.

This device complies with FCC rules. Boston Amplifier provides bi-directional amplification of transmit (uplink from the phone to the service provider) and receive (downlink to the phone from the service provider). This amplification can provide improved portable cellular phone call quality, reliability, and range in marginal signal areas called "Dead Zones".

Features of the Booster Amplifier Include

Depends on your models.

- Models covering Cellular SBX-800NXT, 819 & 1900
- Power LED Indicator
- 4 Feet Cable
- DC Hardwired Power or Cigarette Lighter Cable
- Compact Size and easy vehicle installation
- One Year Warranty

The SBX (Booster Amplifier) is designed for use with cell phones capable of no more than 600 mill watts output. The majority of wireless phones sold meet this requirement. Any attempt to connect higher-powered phone, such as older analog mobile telephones, to the Booster Amplifier will nullify the manufacturer's warranty, result in improper and illegal operation, and can damage the unit and or cell phone.

Note: Please read the entire contents of this installation guide.

Important: The SBX-800NXT, 819 or 1900 can be used with Hands-free kit already installed in vehicle or can be used only with Boston Amplifier's Antenna Port Module (Wireless) with standard off the shelf Cell Phone holder (Cradle). This product is exclusively for use in vehicles, or vessels use with a negative-ground power supply.

Operating Voltage: 12VDC to 35VDC
Power Consumption: Typical Stand By: 350ma
Usage 550ma

Step 1: Placement of Amplifier Unit inside the vehicle, within 4 to 6 ft reach of cigarette lighter, make sure it rests flat, or mounted behind dash board or under the seat with double adhesive tape to secure in place and is not a hazard to driver.

Step 2: DC Power Cable connect in Cigarette Lighter of vehicle or hard wired in vehicle. Connect DC Power Jack to the power connector socket in the amplifier unit.

Note: To avoid the vehicle battery drainage make sure that the amplifier is not receiving any power during the "OFF" stage of Ignition Key.

Step 3: Position of Exterior Antenna on vehicle at rear glass or on the trunk or on the rear top of vehicle as far as back as possible. Connect the cable to Antenna side of the Amplifier.

Step 4: Take 4ft Cable and connect with the hands free kit or directly hard wired to your cell phone or use APM (Antenna Port Module) Position APM in the cradle or holder anywhere in front with the best unobstructed view. Place your cell phone on top of APM in the cradle as a pickup wireless signal and use head set from you cell phone to have communication or within a reach of 4 to 6 feet.

Step 5:Red Power LED is lit as soon as Ignition Switch become activated.

Depend on your Model:

Not far aside the Green LED will go off, including the Red Power LED and RED LED will start blinking.

For further information see SST® Antenna Installation Guide.

Important: *For optimal performance, rear exterior antenna to be mounted vertically and Power LED and Green LED should be ON and not Blinking.*

Vehicle Installation



Figure 2 Copyright© 2002-Present
Installed Wireless Dash Mount

6

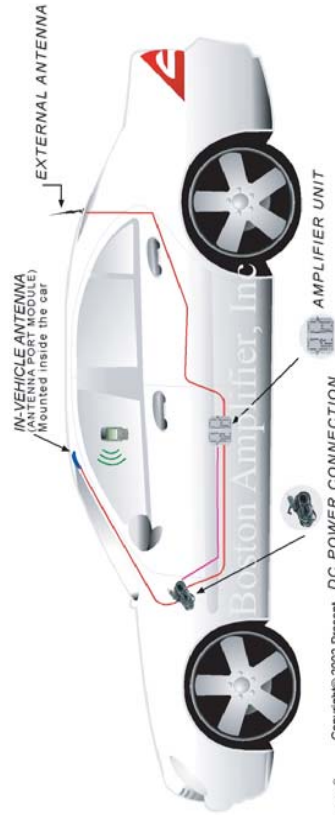

Figure 3 Copyright© 2002-Present
Installed Wireless Under Seat

Limited Warranty

Boston Amplifier warrants to the original purchaser a product free from defects in material and workmanship for a period of One (1) year from the date of purchase.

Under the above warranty, Boston Amplifier, at its option, shall either repair or replace non-conforming or defective products. If Boston Amplifier determines that the product has been misused, carelessly handled, defaced (including unauthorized repairs performed or attempted by others), modified or altered in any way, the warranty will be considered null and void, and the unit will not be repaired or replaced under warranty.

The product must be returned with the proof of purchase to the point of purchase or by obtaining an RMA (Return Merchandise Authorization) number from Boston Amplifier. Claims must be made in accordance with the provisions of this warranty and within the applicable warranty period or they will be disregarded.

No inbound or outbound shipping will be paid, regardless of the territory, by Boston Amplifier neither will its agents, employees, or sales representatives pick up or deliver any defective or non-defective products from customer, distributor or OEM sites. Any product, which is inbound from overseas, must be handled by properly licensed freight forwarders in order to comply with the applicable laws of the United States of America. Boston Amplifier will not be responsible for any product which has been lost or damaged during inbound and outbound shipping. It is customers responsibility to obtain full insurance from the shipping carriers.

Boston Amplifier reserves the ultimate authority to determine what constitutes warranty repair. If it is determined that the product is received after expiration of the warranty period, it will be repaired using Boston Amplifier's standard rates for parts and labor, which may change from time to time.

Cont'd Next Page

Limited Warranty

Boston Amplifier will use its best efforts to repair the product within 15 working days after receipt thereof. Boston Amplifier shall not be responsible for delays caused by shipping or non-availability of replacement parts or other causes, events, or conditions beyond its reasonable control.

The above warranty is the only warranty authorized by Boston Amplifier. The above warranty states the purchaser's exclusive remedy for any breach of the Boston Amplifier warranty and for any claim, whether sounding in contract, tort or negligence, for loss or injury caused by the sale of any product without limiting the generality of the foregoing, shall be limited no more than the replacement value of the Boston Amplifier purchased, or an equivalent product, and only in the event the remedy is being sought by the original purchaser of the Boston Amplifier product in question. Boston Amplifier shall in no event be responsible for any loss of business or profits, downtime or delay, labor, repair, monetary, financial, or material costs, injury to person, persons or property, or any similar or dissimilar consequential loss or damage incurred by the purchaser, even if Boston Amplifier has been advised of the possibilities of such losses or damages.

Boston Amplifier, Inc.

2110 Artesia Blvd Suite B202
Redondo Beach, CA 90278
<http://www.bostonamplifier.com>

Copyright © 2002 -2006 Boston Amplifiers, Inc.
All rights reserved.